

# Product Information Daylight-roller shutter

In-between profiles made from diffuse plastic  
provide selective incidence of daylight

Design with round or square box

The roller shutter is provided with crank handle drive or electric drive



## Product features

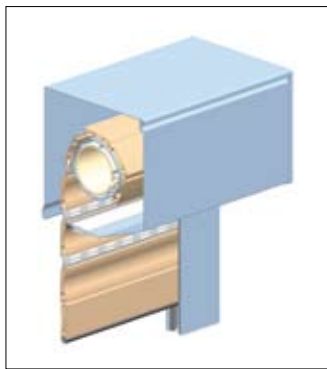

As surface mounted roller shutter with square box.

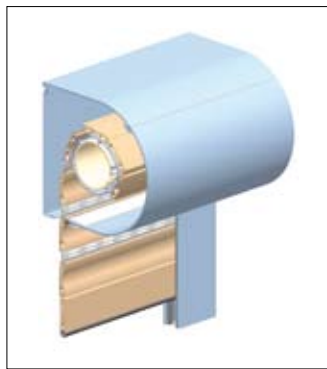

As surface mounted roller shutter with elegant round box.

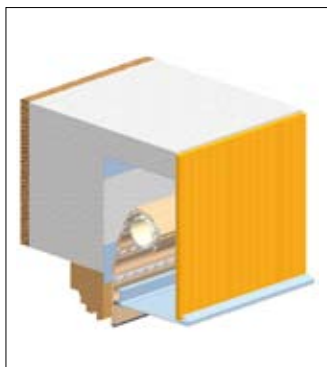

As built-in roller shutter in the "trav" lintel box.

## Steel jacket profile



### Closed daylight roller shutters.

Extruded aluminium shutter profile. Locking plug. End rail with neoprene insert.



### Daylight roller shutters stretched.

Intermediate profile made of diffused, high-grade plastic. Intermediate profile with air vents.

## Limit sizes

weight kg/m <sup>2</sup>	Type	min. width (mm)	max. width (mm)	max. height (mm)	max. surface (m <sup>2</sup> )
9,1	KU	400	2500	2400	2,7
	M	650	2500	2400	5

## Luminance

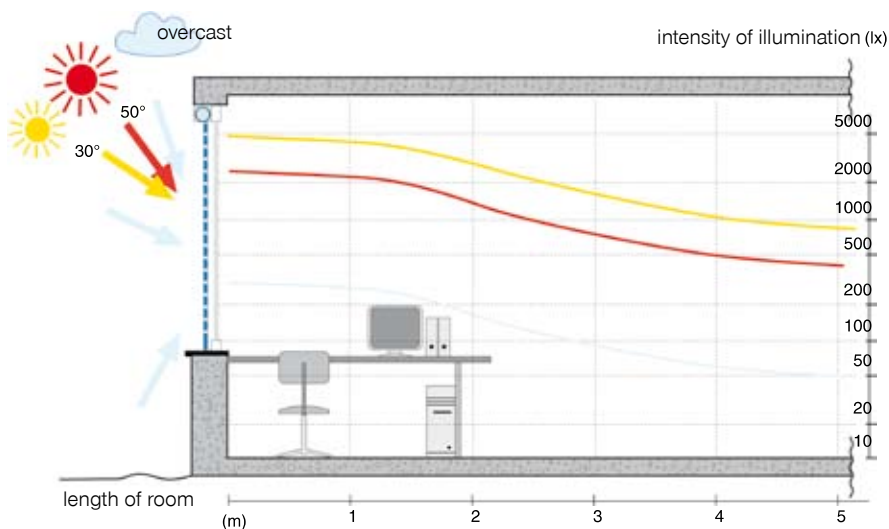

### Luminance [cd/m<sup>2</sup>] \*

	Mittelwert	Spitzenwert
30°	4000	16000
40°	500	2000
bedeckt	180	750

\* **Luminance:** The average values describe the luminance value of the complete roller shutter. The peak values are the values of the plastic profiles.

\* To compare: a luminous intensity of 100 lux is sufficient for convenient reading.

Qualified company:

**Head Office:**  
**HELLA Sonnen- und Wetterschutztechnik GmbH**  
 A-9913 Abfaltersbach 125  
 T. +43 (0)4846 / 65 55-0  
 F. +43 (0)4846 / 65 55-134  
 E: office@hella.info

[www.hella.info](http://www.hella.info)